

## Brewer PH2 Pothanger Fitting Instructions

**Important: ensure you have the correct terminal to match your fuel type and application.**

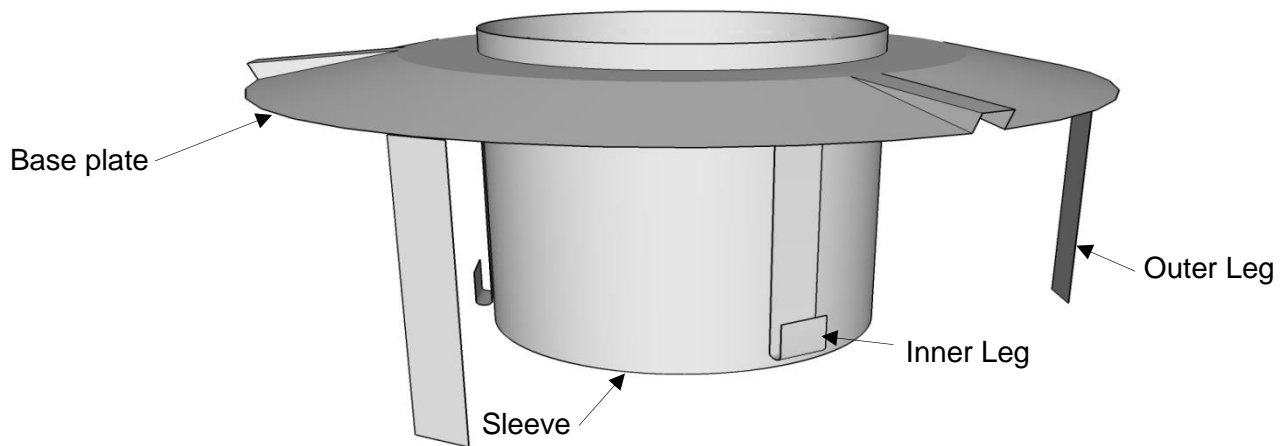

### Attaching the Pothanger to the flue liner

1. Slide the flue liner over the sleeve ensuring the inner legs do not pass into the liner. The flue liner must be pushed up to the top of the inner legs (fig1). If a gas tight seal between the flue liner and sleeve is necessary, specialised sealant (not supplied) between the flue liner and sleeve may be required before assembly.
2. Pass one of the stainless steel bands around the flue liner and through the upturns at the bottom of the inner legs (fig1).
3. Tighten the strap with a screwdriver and trim off any excess strap if necessary.

Note: additional security between the liner and pothanger can be achieved with self-drilling screws, driven through the liner into the sleeve.

### Mounting the Pothanger to the chimney

1. With the flue liner attached to the Pothanger, lower the assembly until the baseplate rests centrally on the top of the chimney.
2. Bend the external legs down the outside face of the chimney. (Fig3)
3. Pass the stainless steel band around the outer legs. (Fig3)
4. Position the stainless steel band approximately 50mm (2") above the lower edge of the outer legs and tighten with a screwdriver.
5. Bend bottom of outer legs back upwards over the stainless steel band and trim if necessary (Fig3).

Fig 1

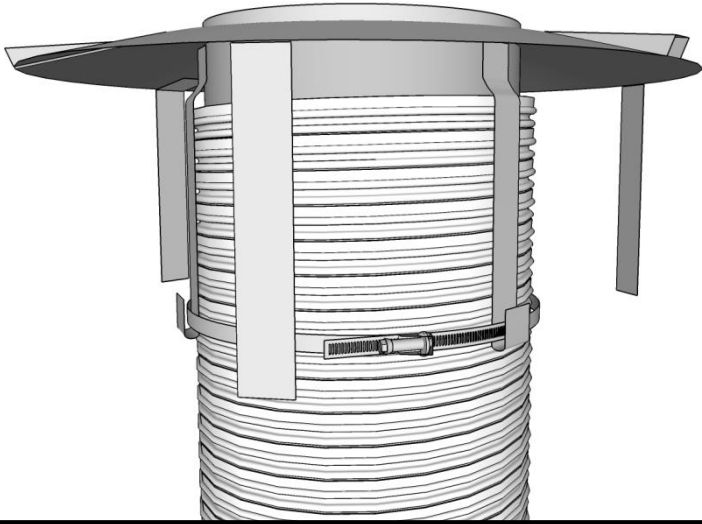

Fig 2

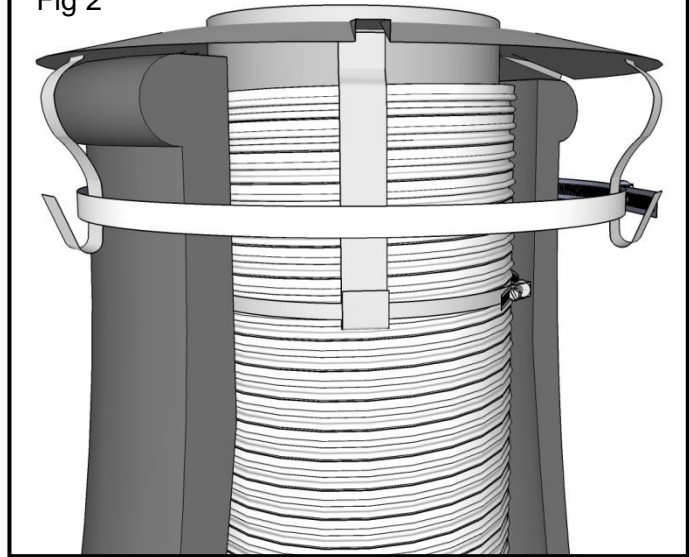
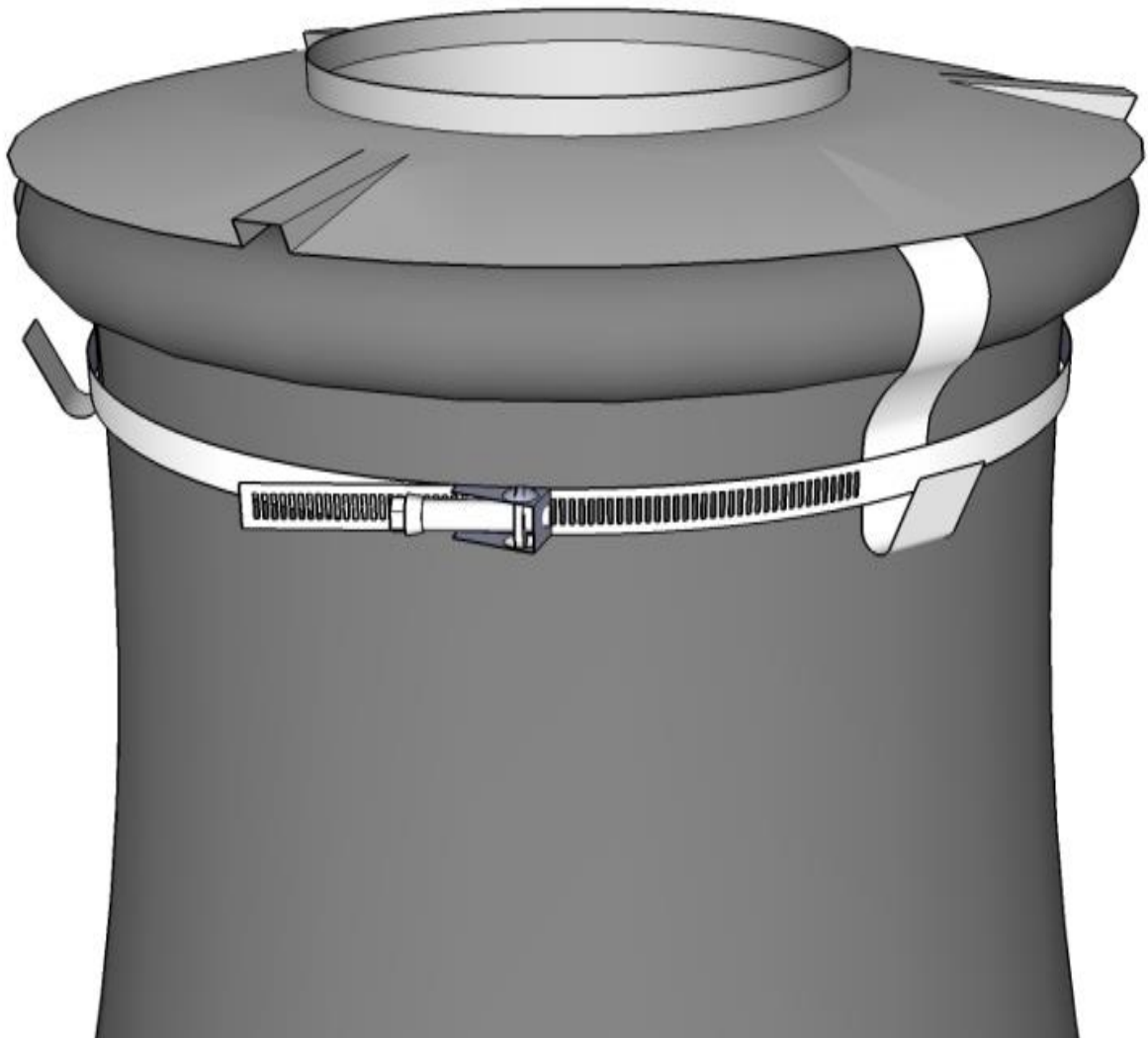

Fig 3



# Declaration of conformity

Brewer Metalcraft Ltd  
Units C&D Ford Lane Industrial Estate  
Ford (Near Arundel)  
West Sussex BN18 0DF  
United Kingdom

13

1856-1:2009 Chimneys - Requirements for metal  
chimneys - Part 1: System chimney products

Metal system chimney fitting - Terminal

| Essential Characteristic    | Performance |
|-----------------------------|-------------|
| Flow resistance Coefficient | N/A         |
| Durability: Freeze thaw     | Pass        |

# Specifications

|                             |                           |       |
|-----------------------------|---------------------------|-------|
| Model                       | PH2 Pothanger             |       |
| Nominal base plate diameter | 310mm                     |       |
| Nominal sleeve diameter     | Model                     |       |
|                             | 125                       | 120mm |
|                             | 150                       | 146mm |
|                             | 178                       | 173mm |
|                             | 200                       | 195mm |
| Material                    | Grade 316 stainless steel |       |

